

Medium Duty Incremental Encoders (SAE Dimension Encoders)

TRDA-20 series

Features

A medium duty encoder that is cost-effective for small applications; has the following features:

- Small body with 2.0 in. diameter and 1.7 in. depth
- 0.375 in. diameter solid shaft
- Resolution available from 100 pulses per revolution to 2500 pulses per revolution
- Totem pole or line driver output
- Up to 100 kHz response frequency (totem pole)
- Up to 200 kHz response frequency (line driver)
- Two-meter cable with tinned ends
- IP50 environmental rating



TRDA-20R1N models

TRDA-20 Medium Duty Solid-shaft Incremental Encoders (Totem-pole and Line-driver Output Models)					
Part Number	Price	Pulses per Revolution	Input Voltage	Output	Body Dia.
TRDA-20R1N100RZD	\$154.00	100	5-30 VDC	Totem-pole sink/source	2.0 in.
TRDA-20R1N360RZD	\$154.00	360			
TRDA-20R1N500RZD	\$154.00	500			
TRDA-20R1N1000RZD	\$154.00	1000			
TRDA-20R1N1024RZD	\$165.00	1024			
TRDA-20R1N2500RZD	\$167.00	2500	5VDC	Line-driver (differential)	
TRDA-20R1N100VD	\$154.00	100			
TRDA-20R1N360VD	\$154.00	360			
TRDA-20R1N500VD	\$154.00	500			
TRDA-20R1N1000VD	\$154.00	1000			
TRDA-20R1N1024VD	\$166.00	1024			
TRDA-20R1N2500VD	\$167.00	2500			

Accessories

Accessories for TRDA-20 Series Encoders *		
Part Number *	Price	Description
TRDA-20R1D	\$27.00	Mounting flange, round, 1.5 inch bolt-hole circle
TRDA-20R2D	\$39.00	Mounting flange, round, 1.625 inch bolt-hole circle
TRDA-20SND	\$59.00	Mounting flange, square
LM-001D**	\$120.00	Mounting bracket for TRDA-20 & TRDA-25 encoders

* The accessories in this table work only with TRDA-20R1Nxxxxx series encoders, unless marked otherwise.

** Use of LM-001D also requires a TRDA-20SND replacement mounting flange, plus four customer-supplied 6-32 x 0.50 in long fasteners.

Couplings

For encoders with a solid shaft, please select a coupling that fits your encoder. All couplings are in stock, ready to ship.

See the "Encoder Couplings" section for more information.



LM-001D

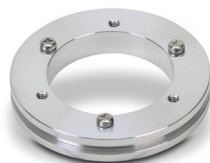

TRDA-20R1D



TRDA-20R2D

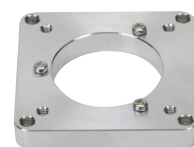

TRDA-20SND

Medium Duty Incremental Encoders (SAE Dimension Encoders)

Specifications – TRDA-20 series

Electrical Specifications (SAE Dimension Medium Duty)				
Model		TRDA-20R1NxxxRZD (Totem-pole)	TRDA-20R1NxxxVD (Line Driver)	
Power Supply	Operating Voltage *	5–30 VDC (nominal) * Range: 4.75–30.0 VDC	5VDC (nominal) * Range: 4.75–5.25 VDC	
	Allowable Ripple	3% rms max		
	Current Consumption	60 mA max		
Output Waveform	Signal Waveform	Quadrature + home position		
	Max. Response Frequency	100 kHz	200 kHz	
	Operating Speed	(max response frequency / resolution) x 60		
	Duty Ratio (Symmetry)	50% ±25%		
	Index Signal Width (at home position)	100% ±50%		
Output	Rise/Fall Time **	3µs max **	100 ns max **	
	Output Type	Totem-pole	Line driver (26C31 or equivalent)	
	Output Current	Inflow	30 mA max	20 mA max
		Outflow	10 mA max	
	Output Voltage	H	[(power voltage voltage) - (2.5V)] min	2.5V min
		L	0.4V max	0.5V max
	Load Power Supply Voltage	35 VDC max		–
Short-Circuit Protection	between each output and 0V terminal		–	
* To be supplied by Class II source. ** With a cable of 2m or less; Max load.				
Mechanical Specifications				
Starting Torque	0.003 N·m (0.002 lb-ft) max @ 20 °C [68 °F]			
Max Allowable Shaft Load	Radial: 50N (11.2 lb); Axial: 30N (6.7 lb)			
Max Allowable Speed	5000 rpm (max speed that the mechanical integrity of encoder can support)			
Wire Size	0.2 mm ² [24 AWG] shielded, oil-resistant PVC			
Mounting Orientation	can be mounted in any orientation			
Weight	approx 270g (9.52 oz) [with 2m cable]			
Environmental Specifications				
Ambient Temperature	-10 to 70 °C [14 to 158 °F]			
Storage Temperature	-25 to 85 °C [-13 to 185 °F]			
Operating Humidity	35 to 85 %RH			
Voltage Withstand	500 VAC @ 50/60Hz for one minute	grounded through capacitor		
Insulation Resistance	50 MΩ min (excluding shield)			
Vibration Resistance	10 to 55 Hz with 0.75 mm half amplitude; durable for one hour along three axes			
Shock Resistance	11 ms ~ 500 P/R metal slit 981 m/s ² applied three times along three axes 11 ms ~ 600 P/R glass slit 490 m/s ² applied three times along three axes			
Protection	IP50			
Agency Approvals	cUL _{US} (E189395)			

Medium Duty Incremental Encoders (SAE Dimension Encoders)

Specifications – TRDA-20 series

Wiring Diagrams

Totem Pole Connections

Cable shield is connected to the encoder body (frame ground)

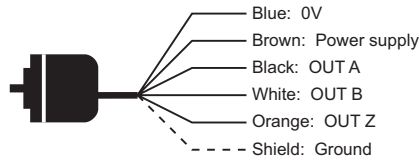

Line Driver Connections

Cable shield is connected to the encoder body (frame ground)

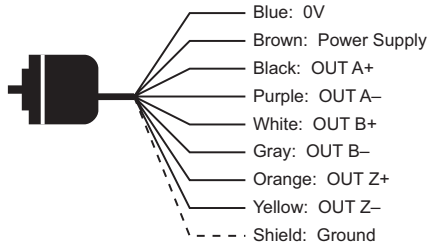

How to read the timing charts

Totem Pole Models

Out A and Out B are 90 degrees out of phase. Like any quadrature encoder, four unique logic states are created internally to the encoder. This is based on the rising edge to rising edge (one cycle) on channel A or B that indicates one set of bars on the internal encoder disk has passed by the optical sensor.

OUT Z is the absolute reference added to an incremental encoder and is also known as home position. It signifies a full rotation of the encoder shaft.

Line Driver Models

Channel A (OUT A and A-not) and Channel B (OUT B and B-not) are also 90 degrees out of phase on line driver encoders. OUT Z is the same as on open collector models, and is the absolute reference (home position). It signifies one full rotation of the encoder shaft.

Channel Timing Charts

Totem Pole Models (TRDA-20R1NxxxRZD)

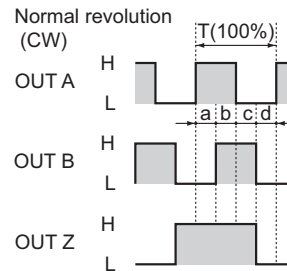

$a, b, c, d = 1/4T \pm 1/8T$

"Normal" means clockwise revolution viewed from the shaft

Line Driver Models (TRDA-20R1NxxxVD)

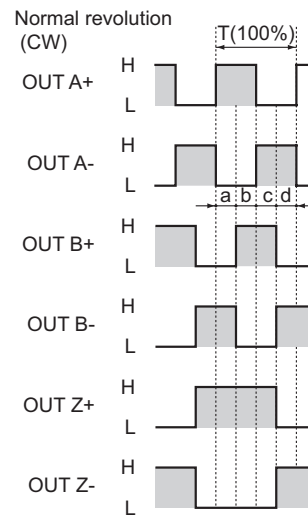

$a, b, c, d = 1/4T \pm 1/8T$

"Normal" means clockwise revolution viewed from the shaft

Medium Duty Incremental Encoders (SAE Dimension Encoders)

Dimensions – TRDA-20 series

Dimensions = in [mm]

TRDA-20R1NxxxxxD

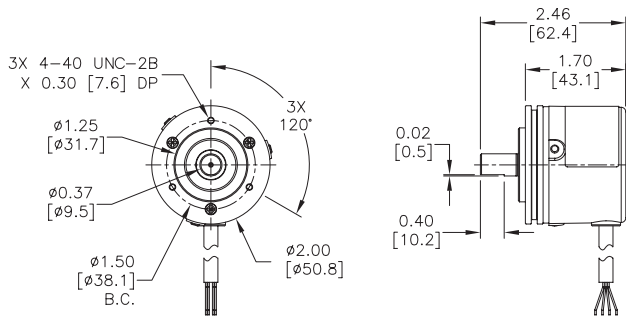

LM-001D Mounting Bracket

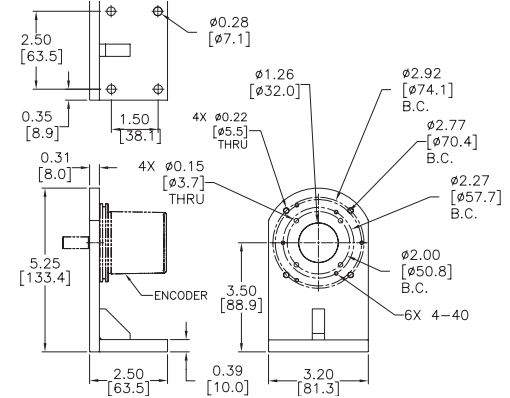

TRDA-20R1D Mounting Flange

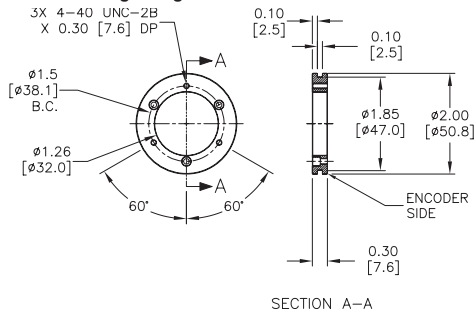

TRDA-20R2D Mounting Flange

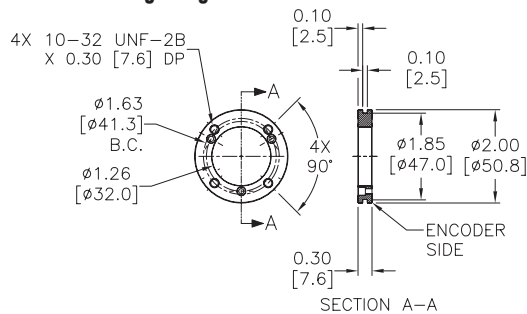

TRDA-20SND Mounting Flange

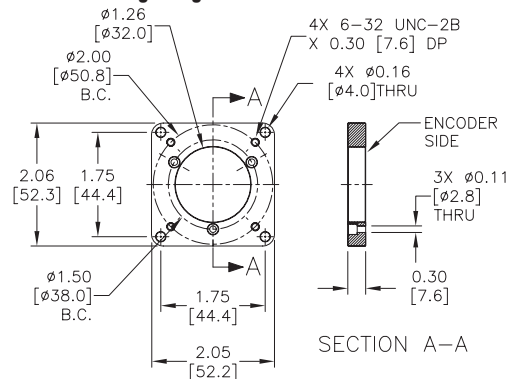

Medium Duty Incremental Encoders (SAE Dimension Encoders)

TRDA-25 series

Features

A medium duty encoder that is cost-effective for small applications; has the following features:

- Small body with 2.0 in. diameter and 2.15 in. depth
- 0.375 in diameter solid shaft
- Removable 2.5 in. round flange
- Resolution available from 100 pulses per revolution to 2500 pulses per revolution
- Totem pole or line driver output
- Up to 100 kHz response frequency (totem pole)
- Up to 200 kHz response frequency (line driver)
- Military-style connector (cable sold separately)
- IP65 environmental rating



TRDA-25 models

Accessories

Couplings

For encoders with a solid shaft, please select a coupling that fits your encoder. All couplings are in stock, ready to ship.

See the "Encoder Couplings" section for more information on.



TRDA-25-CON-RZWD



TRDA-25-CON-VWD



LM-001D



TRDA-25CBL-RZWD

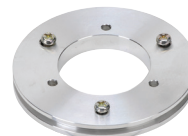

TRDA-25RND

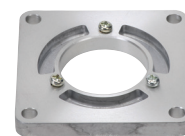

TRDA-25SND



TRDA-25CBL-VWD

TRDA-25 Medium Duty Solid-shaft Incremental Encoders – (Totem-pole and Line-driver Output Models) – MS Connector *					
Part Number *	Price	Pulses per Revolution	Input Voltage	Output	Body Dia.
TRDA25RN100RZWDMS	\$248.00	100	5–30 VDC	Totem-pole sink/source	2.0 in. (2.5 in. round flange)
TRDA25RN360RZWDMS	\$248.00	360			
TRDA25RN500RZWDMS	\$248.00	500			
TRDA25RN1000RZWDMS	\$248.00	1000			
TRDA25RN1024RZWDMS	\$248.00	1024			
TRDA25RN2500RZWDMS	\$268.00	2500	5VDC	Line-driver (differential)	
TRDA25RN100VWDM	\$248.00	100			
TRDA25RN360VWDM	\$248.00	360			
TRDA25RN500VWDM	\$248.00	500			
TRDA25RN1000VWDM	\$248.00	1000			
TRDA25RN1024VWDM	\$248.00	1024			
TRDA25RN2500VWDM	\$269.00	2500			

* TRDA25RNxxxxWDMS encoders do NOT include cables or connectors, which are sold separately in the "Accessories" section.

Accessories for TRDA-25 Series Encoders *		
Part Number *	Price	Description
TRDA-25RND	\$39.00	Mounting flange, round (2.5 in. dia. w/ 1.88 in B.C.)
TRDA-25SND	\$39.00	Mounting flange, square (2.5 in. dia.)
TRDA-25CON-RZWD	\$55.00	Connector for TRDA-25RNxxxRZWD-MS, Totem Pole output, 7-pin MS connector
TRDA-25CBL-RZWD-10**	\$96.00	Cable for TRDA-25RNxxxRZWD-MS, Totem Pole output, 7-pin MS connector, 10 ft
TRDA-25CBL-RZWD-20**	\$118.00	Cable for TRDA-25RNxxxRZWD-MS, Totem Pole output, 7-pin MS connector, 20 ft
TRDA-25CBL-RZWD-30**	\$134.00	Cable for TRDA-25RNxxxRZWD-MS, Totem Pole output, 7-pin MS connector, 30 ft
TRDA-25CON-VWD	\$61.00	Connector for TRDA-25RNxxxVWD-MS, Line Driver output, 10-pin MS connector
TRDA-25CBL-VWD-10**	\$114.00	Cable for TRDA-25RNxxxVWD-MS, Line Driver output, 10-pin MS connector, 10 ft
TRDA-25CBL-VWD-20**	\$114.00	Cable for TRDA-25RNxxxVWD-MS, Line Driver output, 10-pin MS connector, 20 ft
TRDA-25CBL-VWD-30**	\$119.00	Cable for TRDA-25RNxxxVWD-MS, Line Driver output, 10-pin MS connector, 30 ft
LM-001D***	\$120.00	Mounting bracket for TRDA-20 & TRDA-25 encoders

[‡] The accessories in this table work only with TRDA-25RNxxxxWD-MS series encoders, unless marked otherwise.
^{**} Cables have IP65 environmental rating.
^{***} Use of LM-001D also requires a TRDA-25SND replacement mounting flange, plus four customer-supplied 6-32 x 0.50 in long fasteners.

Medium Duty Incremental Encoders (SAE Dimension Encoders)

Specifications – TRDA-25 series

Electrical Specifications – TRDA-25 (SAE Dimension Medium Duty)				
Model		TRDA25RNxxxRZWDMS (Totem-pole)	TRDA25RNxxxVWDMS (Line Driver)	
Power Supply	Operating Voltage *	5–30 VDC (nominal) * Range: 4.75–30.0 VDC	5VDC (nominal) * Range: 4.75–5.25 VDC	
	Allowable Ripple	3% rms max		
	Current Consumption	60 mA max		
Output Waveform	Signal Waveform	Quadrature + home position		
	Max. Response Frequency	100 kHz	200 kHz	
	Operating Speed	(max response frequency / resolution) x 60		
	Duty Ratio (Symmetry)	50% ±25%		
	Index Signal Width (at home position)	100% ±50%		
Output	Rise/Fall Time **	3µs max **	100 ns max **	
	Output Type	Totem-pole	Line driver (26C31 or equivalent)	
	Output Current	Inflow	30 mA max	20 mA max
		Outflow	10 mA max	
	Output Voltage	H	[(power voltage voltage) - (2.5V)] min	2.5V min
		L	0.4V max	0.5V max
	Load Power Supply Voltage	35 VDC max	–	
Short-Circuit Protection	between each output and 0V terminal	–		
* To be supplied by Class II source. ** With a cable of 2m or less; Max load.				
Mechanical Specifications				
Starting Torque		0.05 N·m [0.04 lb·ft] @ 20 °C [68 °F]		
Max Allowable Shaft Load		Radial: 50N [11.2 lb]; Axial: 30N [6.7 lb]		
Max Allowable Speed		3000 rpm (max speed that the mechanical integrity of encoder can support)		
Wire Size		–		
Mounting Orientation		can be mounted in any orientation		
Weight		approx 280g [9.88 oz]		
Environmental Specifications				
Ambient Temperature		-10 to 70 °C [14 to 158 °F]		
Storage Temperature		-25 to 85 °C [-13 to 185 °F]		
Operating Humidity		35 to 85 %RH		
Voltage Withstand		500 VAC @ 50/60Hz for one minute	grounded through capacitor	
Insulation Resistance		50 MΩ min (excluding shield)		
Vibration Resistance		10 to 55 Hz with 0.75 mm half amplitude; durable for one hour along three axes		
Shock Resistance		11 ms ~ 500 P/R metal slit 981 m/s ² applied three times along three axes 11 ms ~ 600 P/R glass slit 490 m/s ² applied three times along three axes		
Protection		IP65		
Agency Approvals		cUL _{US} (E189395)		

Medium Duty Incremental Encoders (SAE Dimension Encoders)

Specifications – TRDA-25 series

Connector Pin-out

TRDA25RNxxxRZWDMS (Totem Pole)		
Connector	Pin	Signal
 <p>Viewed from wiring side (rear)</p>	A	Out A
	B	Out B
	C	Out Z
	D	Power Supply
	E	n.c.
	F	0V
	G	ground
A shielding wire is connected to frame ground.		

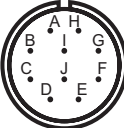
TRDA25RNxxxVWDMS (Line Driver)		
Connector	Pin	Signal
 <p>Viewed from wiring side (rear)</p>	A	Out A+
	B	Out B+
	C	Out Z+
	D	Power Supply
	E	n.c.
	F	0V
	G	ground
	H	Out A-
	I	Out B-
	J	Out Z-
A shielding wire is connected to frame ground.		

How to read the timing charts

Totem Pole Models

Out A and Out B are 90 degrees out of phase. Like any quadrature encoder, four unique logic states are created internally to the encoder. This is based on the rising edge to rising edge (one cycle) on channel A or B that indicates one set of bars on the internal encoder disk has passed by the optical sensor.

OUT Z is the absolute reference added to an incremental encoder and is also known as home position. It signifies a full rotation of the encoder shaft.

Line Driver Models

Channel A (OUT A and A-not) and Channel B (OUT B and B-not) are also 90 degrees out of phase on line driver encoders. OUT Z is the same as on open collector models, and is the absolute reference (home position). It signifies one full rotation of the encoder shaft.

Channel Timing Charts

Totem Pole Models (TRDA25RNxxxRZWDxx)

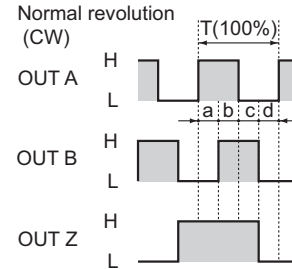

$a, b, c, d = 1/4T \pm 1/8T$
"Normal" means clockwise revolution viewed from the shaft

Line Driver Models (TRDA25RNxxxVWDxx)

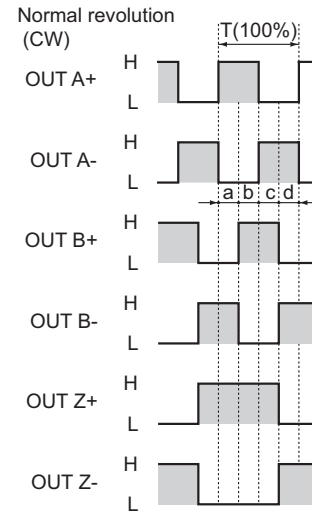

$a, b, c, d = 1/4T \pm 1/8T$
"Normal" means clockwise revolution viewed from the shaft

Medium Duty Incremental Encoders (SAE Dimension Encoders)

Dimensions – TRDA-25 series

Dimensions = in [mm]

TRDA25RN Encoder

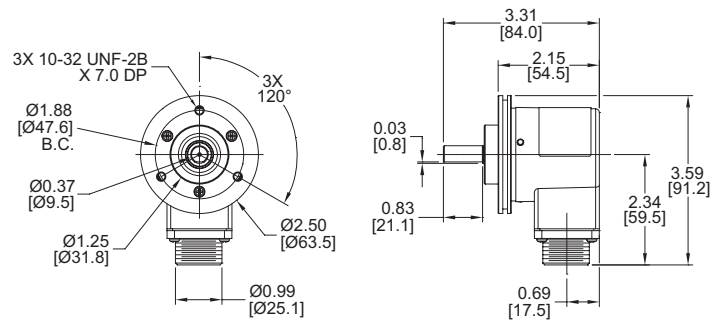

TRDA-25RND Mounting Flange

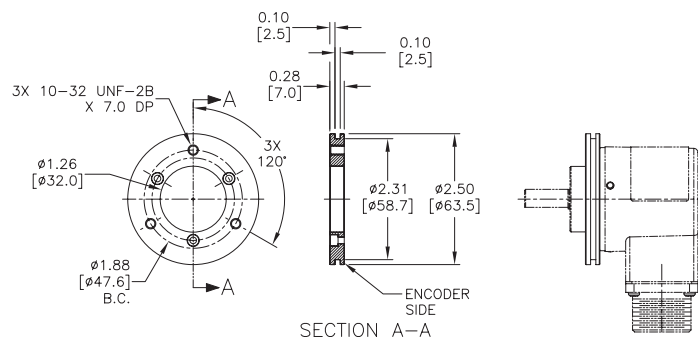

TRDA-25SND Mounting Flange

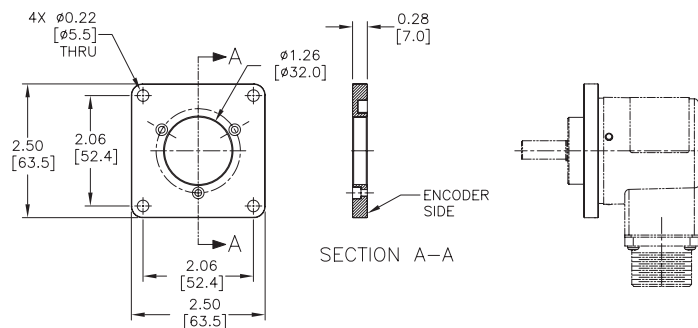

Medium Duty Incremental Encoders (Metric Dimension Encoders)

TRD-N(H) series

Features

The medium duty encoder offers the greatest flexibility of choice in a very high-quality encoder, all for a very low price. Features:

- Small body with 50 mm diameter and 35 mm depth
- Splash proof (IP65 rating)
- 8 mm solid shaft or 8 mm hollow shaft
- Incremental resolution available from 3 pulses per revolution to 5,000 pulses per revolution
- Line driver or Totem-pole (push-pull) output
- Up to 200 kHz response frequency



Solid-shaft (TRD-N) model



Hollow-shaft (TRD-NH) model

Incremental Medium Duty Solid Shaft Encoders (Totem-pole Output, TRD-Nxxx-RZWD)					
Part Number	Price	Pulses per Revolution	Input Voltage	Output	Body Dia.
TRD-N3-RZWD	\$160.00	3	5-30 VDC	Totem-pole (push-pull) sink/source	50 mm
TRD-N4-RZWD	\$160.00	4			
TRD-N5-RZWD	\$160.00	5			
TRD-N10-RZWD	\$160.00	10			
TRD-N30-RZWD	\$160.00	30			
TRD-N40-RZWD	\$160.00	40			
TRD-N50-RZWD	\$160.00	50			
TRD-N60-RZWD	\$160.00	60			
TRD-N100-RZWD	\$160.00	100			
TRD-N120-RZWD	\$180.00	120			
TRD-N200-RZWD	\$180.00	200			
TRD-N240-RZWD	\$180.00	240			
TRD-N250-RZWD	\$180.00	250			
TRD-N300-RZWD	\$180.00	300			
TRD-N360-RZWD	\$180.00	360			
TRD-N400-RZWD	\$180.00	400			
TRD-N480-RZWD	\$180.00	480			
TRD-N500-RZWD	\$180.00	500			
TRD-N600-RZWD	\$180.00	600			
TRD-N750-RZWD	\$180.00	750			
TRD-N1000-RZWD	\$180.00	1000			
TRD-N1024-RZWD	\$180.00	1024			
TRD-N1200-RZWD	\$235.00	1200			
TRD-N2000-RZWD	\$235.00	2000			
TRD-N2500-RZWD	\$236.00	2500			
TRD-N3000-RZWD	\$236.00	3000			
TRD-N3600-RZWD	\$236.00	3600			
TRD-N5000-RZWD	\$236.00	5000			

Incremental Medium Duty Hollow Shaft Encoders (Totem-pole Output, TRD-NHxxx-RZWD)					
Part Number	Price	Pulses per Revolution	Input Voltage	Output	Body Dia.
TRD-NH3-RZWD	\$180.00	3	5-30 VDC	Totem-pole (push-pull) sink/source	50 mm
TRD-NH4-RZWD	\$180.00	4			
TRD-NH5-RZWD	\$180.00	5			
TRD-NH10-RZWD	\$180.00	10			
TRD-NH30-RZWD	\$180.00	30			
TRD-NH40-RZWD	\$180.00	40			
TRD-NH50-RZWD	\$180.00	50			
TRD-NH60-RZWD	\$180.00	60			
TRD-NH100-RZWD	\$180.00	100			
TRD-NH120-RZWD	\$200.00	120			
TRD-NH200-RZWD	\$200.00	200			
TRD-NH240-RZWD	\$200.00	240			
TRD-NH250-RZWD	\$200.00	250			
TRD-NH300-RZWD	\$200.00	300			
TRD-NH360-RZWD	\$200.00	360			
TRD-NH400-RZWD	\$200.00	400			
TRD-NH480-RZWD	\$200.00	480			
TRD-NH500-RZWD	\$200.00	500			
TRD-NH600-RZWD	\$205.00	600			
TRD-NH750-RZWD	\$205.00	750			
TRD-NH1000-RZWD	\$205.00	1000			
TRD-NH1024-RZWD	\$201.00	1024			
TRD-NH1200-RZWD	\$251.00	1200			
TRD-NH2000-RZWD	\$251.00	2000			
TRD-NH2500-RZWD	\$251.00	2500			
TRD-NH3000-RZWD	\$255.00	3000			
TRD-NH3600-RZWD	\$251.00	3600			
TRD-NH5000-RZWD	\$255.00	5000			

Medium Duty Incremental Encoders (Metric Dimension Encoders)

TRD-N(H) series

Incremental Medium Duty Solid Shaft Encoders (Line Driver Output, TRD-Nxxx-RZVWD)					
Part Number	Price	Pulses per Revolution	Input Voltage	Output	Body Dia.
TRD-N3-RZVWD	\$167.00	3	5VDC	Line driver (differential)	50 mm
TRD-N4-RZVWD	\$167.00	4			
TRD-N5-RZVWD	\$167.00	5			
TRD-N10-RZVWD	\$167.00	10			
TRD-N30-RZVWD	\$167.00	30			
TRD-N40-RZVWD	\$167.00	40			
TRD-N50-RZVWD	\$167.00	50			
TRD-N60-RZVWD	\$167.00	60			
TRD-N100-RZVWD	\$167.00	100			
TRD-N120-RZVWD	\$198.00	120			
TRD-N200-RZVWD	\$198.00	200			
TRD-N240-RZVWD	\$198.00	240			
TRD-N250-RZVWD	\$198.00	250			
TRD-N300-RZVWD	\$198.00	300			
TRD-N360-RZVWD	\$198.00	360			
TRD-N400-RZVWD	\$198.00	400			
TRD-N480-RZVWD	\$198.00	480			
TRD-N500-RZVWD	\$198.00	500			
TRD-N600-RZVWD	\$198.00	600			
TRD-N750-RZVWD	\$198.00	750			
TRD-N1000-RZVWD	\$200.00	1000			
TRD-N1024-RZVWD	\$200.00	1024			
TRD-N1200-RZVWD	\$235.00	1200			
TRD-N2000-RZVWD	\$235.00	2000			
TRD-N2500-RZVWD	\$235.00	2500			
TRD-N3000-RZVWD	\$236.00	3000			
TRD-N3600-RZVWD	\$236.00	3600			
TRD-N5000-RZVWD	\$236.00	5000			

Incremental Medium Duty Hollow Shaft Encoders (Line Driver Output, TRD-NHxxx-RZVWD)					
Part Number	Price	Pulses per Revolution	Input Voltage	Output	Body Dia.
TRD-NH3-RZVWD	\$180.00	3	5VDC	Line driver (differential)	50 mm
TRD-NH4-RZVWD	\$180.00	4			
TRD-NH5-RZVWD	\$180.00	5			
TRD-NH10-RZVWD	\$180.00	10			
TRD-NH30-RZVWD	\$180.00	30			
TRD-NH40-RZVWD	\$180.00	40			
TRD-NH50-RZVWD	\$180.00	50			
TRD-NH60-RZVWD	\$180.00	60			
TRD-NH100-RZVWD	\$180.00	100			
TRD-NH120-RZVWD	\$198.00	120			
TRD-NH200-RZVWD	\$198.00	200			
TRD-NH240-RZVWD	\$198.00	240			
TRD-NH250-RZVWD	\$198.00	250			
TRD-NH300-RZVWD	\$198.00	300			
TRD-NH360-RZVWD	\$198.00	360			
TRD-NH400-RZVWD	\$198.00	400			
TRD-NH480-RZVWD	\$198.00	480			
TRD-NH500-RZVWD	\$198.00	500			
TRD-NH600-RZVWD	\$217.00	600			
TRD-NH750-RZVWD	\$217.00	750			
TRD-NH1000-RZVWD	\$217.00	1000			
TRD-NH1024-RZVWD	\$217.00	1024			
TRD-NH1200-RZVWD	\$251.00	1200			
TRD-NH2000-RZVWD	\$251.00	2000			
TRD-NH2500-RZVWD	\$251.00	2500			
TRD-NH3000-RZVWD	\$251.00	3000			
TRD-NH3600-RZVWD	\$251.00	3600			
TRD-NH5000-RZVWD	\$251.00	5000			

Wiring diagrams

Totem-pole (push-pull) connections

Cable shield is not connected to the encoder body; enclosure is grounded through the 0V wire

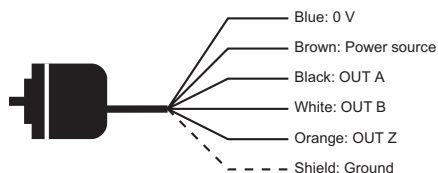

Line driver connections

Cable shield is not connected to the encoder body; enclosure is grounded through the 0V wire

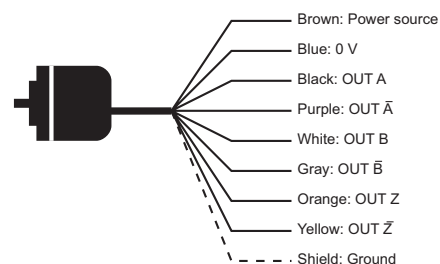

Medium Duty Incremental Encoders (Metric Dimension Encoders)

Specifications – TRD-N(H) series

Electrical Specifications				
Model		TRD-N(H)xxxx-RZWD (Totem-pole)	TRD-N(H)xxxx-RZVWD (Line Driver)	
Power Supply	Operating Voltage *	5–30 VDC (nominal) * Range: 4.75–30.0 VDC	5VDC (nominal) * Range: 4.75–5.25 VDC	
	Allowable Ripple	3% rms max.		
	Current Consumption	60 mA max.		
Signal Waveform		Quadrature + home position		
Max. Response Frequency		100 kHz	100kHz for ≤ 3000 ppr 200kHz for > 3000 ppr	
Operating Speed		(max response frequency / resolution) x 60		
Duty Ratio		50% ±25% (square wave)		
Signal Width at Home Position		100% ±50%		
Output	Rise/Fall Time **	3µs max **	100 ns max **	
	Output Type	Totem Pole (Push Pull)	Line Driver (26C31 or equivalent)	
	Output Current	Negative logic (active low)	Positive logic (active high)	
	Output Current	“H” (inflow)	30 mA max.	20 mA max
		“L” (outflow)	10 mA max.	
	Output Voltage	“H”	[(Load power volt) - 2.5V]	2.5V min
“L”		0.4V max	0.5V max	
Load Power Voltage		35 VDC max	–	

* To be supplied by Class II source

** Cable length ≤2m or less. Maximum load.

Mechanical Specifications

Starting Torque	N (solid shaft): 0.02 N·m [0.18 lb-ft]; NH (hollow shaft): 0.05 N·m [0.44 lb-ft]
Max. Allowable Shaft Load	Radial: 50N [11.24 lb]; Axial: 30N [6.74 lb]
Max. Allowable Speed	Continuous: 3,000 rpm; Instantaneous: 5,000 rpm
Wire Size	24 AWG
Weight	Approx. 270g [9.52 oz] with 2m cable

Environmental Specifications

Ambient Temperature	-10 to 70 °C [14 to 158 °F]	
Storage Temperature	-25 to 85 °C [-13 to 185 °F]	
Operating Humidity	35–85% RH	
Withstand Voltage *	500 VAC (50/60Hz) for one minute *	Grounded through a capacitor
Insulation Resistance	50 MΩ min. (excluding shield between power supply, signal cable and case)	
Vibration Resistance	durable for one hour along three axes at 10 to 55 Hz with 0.75 mm amplitude (excluding shield between power supply, signal cable and case)	
Shock Resistance	≤500 ppr (metal slit) = 11 ms with 981 m/s ² applied three times along three axes ≥600 ppr (glass slit) = 11 ms with 490 m/s ² applied three times along three axes	
Mounting Orientation	can be mounted in any orientation	
Protection	IP65	
Agency Approvals	cUL _{US} (E189395)	

* Voltage withstand is good for power supply, signal, and case; not good for shield wire.

Output Signal Timing Chart - Totem Pole Models

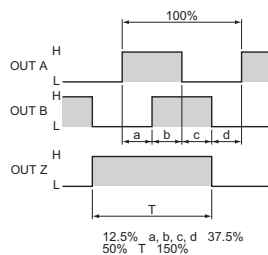

The above waveforms apply to normal (clockwise) revolution viewed from the shaft. OUT Z phase is reversed on the RZL and RZWL models.

Channel timing chart

Accessories

Couplings

For encoders with a solid shaft, please select a coupling that fits your encoder. All couplings are typically in stock, ready to ship.

See the “Encoder Couplings” section for more information.

Mounting Flange & Brackets

Mounting Accessories		
Part #	Price	Description
JT-035D	\$18.00	Mounting Bracket: Metal; for use with all TRD-N/NH/NA encoders
NM-9D*	\$8.00	Mounting Clamp: Metal; for use with all TRD-N/NA encoders *
NF-55D*	\$20.00	Mounting Flange Kit: includes aluminum flange & NM-9D clamp; for use with all TRD-N/NA encoders *
TRD-NH-BKT	\$6.50	Flexible mounting bracket, replacement. For use with Koyo TRD-NH series hollow shaft encoders

* Order NF-55D (flange & clamp) for new installations.
Order NM-9D (clamp) for replacement parts only.

TRD-NH-BKT



NM-9D



JT-035D



NF-55D

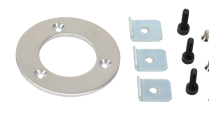

How to read the timing charts

Totem Pole Models

Out A and Out B are 90 degrees out of phase. Like any quadrature encoder, four unique logic states are created internally to the encoder. This is based on the rising edge to rising edge (one cycle) on channel A or B that indicates one set of bars on the internal encoder disk has passed by the optical sensor.

OUT Z is the absolute reference added to an incremental encoder and is also known as home position. It signifies a full rotation of the encoder shaft.

Line Driver Models

Channel A (OUT A and A-not) and Channel B (OUT B and B-not) are also 90 degrees out of phase on line driver encoders. OUT Z is the same as on open collector models, and is the absolute reference (home position). It signifies one full rotation of the encoder shaft.

Medium Duty Absolute and Incremental Encoders (Metric Dimension Encoders)

Dimensions – TRD-N(H) & TRD-NA series

The following are the external dimensions of both incremental and absolute medium duty encoders and optional mounting accessories.

Solid Shaft Incremental and Absolute Encoders (TRD-N, TRD-NA)

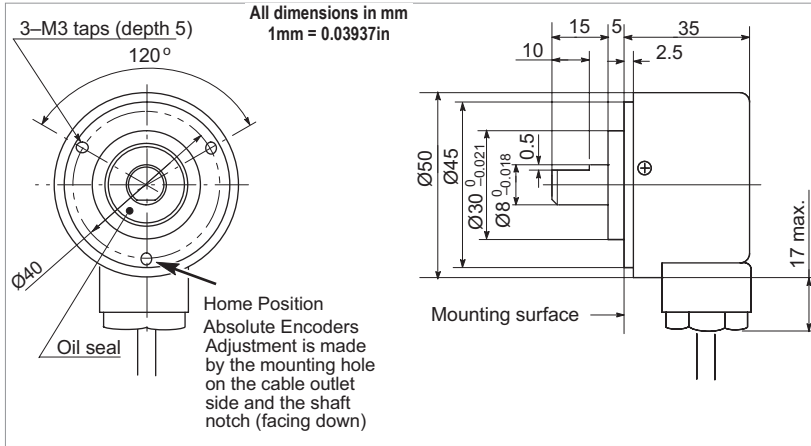

Hollow Shaft Incremental Encoders only (TRD-NH)

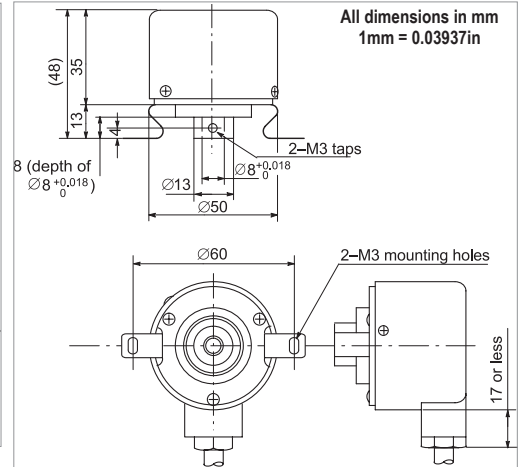

Optional Mounting Flange and Brackets for Medium Duty Encoders

NOTE: NF-55D flange & included NM-9D bracket: Requires (3) M4 x 0.7 tapped holes equally spaced on a 64mm bolt circle in the mounting surface.

JT-035D (bracket)

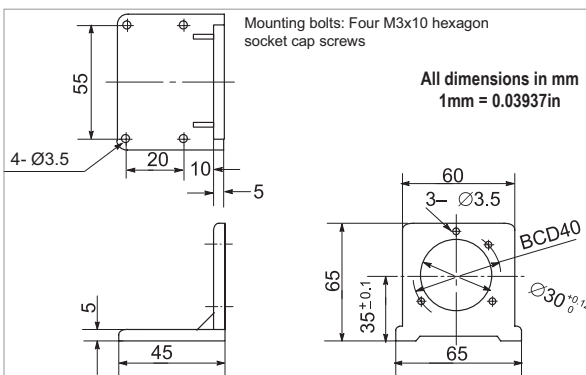

NF-55D (flange)

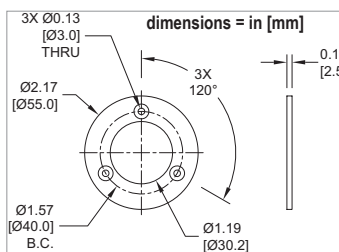

NM-9D (clamp)(included with NF-55D)

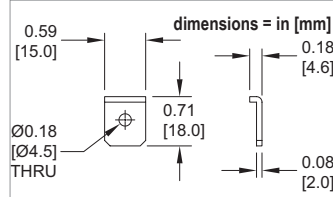

TRD-NH-BKT (bracket)

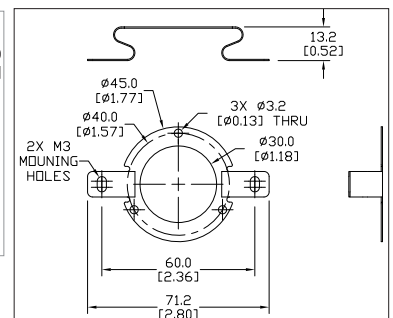

Encoder Accessories – Couplings

Encoder Couplings

Couplings provide a connection between solid-shaft encoders and solid shafts. We offer aluminum, fiberglass, and polymer couplings for metric, S.A.E. and metric-to-S.A.E. applications.

Misalignment compensation

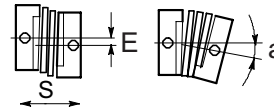

Couplings Selection Guide and Dimensions																
Type	Part Number	Price	Applicable Encoders (shaft size)	Shaft Diameter		D	L	F	C	M	a	E	S	Working Torque (N·m)	Torsional Rigidity	Material
				d1	d2	(mm [in])					max					
								(mm [in])								
Fiberglass (metric)	GJ-4D	\$12.00	TRD-MX (4mm)	4mm	4mm	13 [0.51]	21 [0.83]	5.3 [0.21]	3 [0.12]	M3 set screw	5°	0.4 [0.02]	0.4 [0.02]	0.6 N·m	6 N·m/rad	Glass-fiber reinforced resin
	GJ-6D	\$9.25	TRD-S/SR (6mm)	6mm	6mm	15 [0.59]	22 [0.87]	5.2 [0.20]	3 [0.12]	M3 set screw	6°	0.5 [0.02]	0.12 [0.005]	0.8 N·m	10 N·m/rad	
	GJ-8D	\$11.00	TRD-N/NA (8mm)	8mm	8mm	19 [0.75]	24 [0.94]	6.8 [0.27]	3.5 [0.14]	M4 set screw	5°	0.5 [0.02]	0.4 [0.016]	1.5 N·m	20 N·m/rad	
	GJ-10D	\$12.00	TRD-GK (10 mm)	10 mm	10 mm	22 [0.87]	26 [1.02]	7.1 [0.28]	4 [0.16]	M4 set screw	5°	0.5 [0.02]	0.12 [0.005]	2.0 N·m	32 N·m/rad	
Fiberglass (SAE)	GJ-635D	\$22.00	TRDA-2E (0.25 in)	0.25 in	0.25 in	15 [0.59]	22 [0.87]	5.2 [0.20]	3 [0.12]	M3 set screw	5°	0.5 [0.02]	0.12 [0.005]	0.8 N·m	10 N·m/rad	Glass-fiber reinforced resin
	GJK-953D	\$27.00	TRDA-20/25 (0.375 in)	0.375 in	0.375 in	25 [0.98]	32 [1.26]	7.3 [0.29]	3.5 [0.14]	M4 set screw	5°	0.5 [0.02]	0.12 [0.005]	2.0 N·m	32 N·m/rad	
Polymer (SAE)	STP-MTRA-SC-1412	\$30.00	TRDA-2E (0.25 in)	0.25 in	0.50 in	25 [0.98]	38 [1.50]	9.9 [0.39]	5.4 [0.21]	M3 cap screw	5°	0.3 [0.01]	0.12 [0.005]	3.7 N·m	0.36 °/lb·in	Engineered polymer
	STP-MTRA-SC-3812	\$30.00	TRDA-20/25 (0.375 in)	0.375 in	0.50 in	25 [0.98]	38 [1.50]	9.9 [0.39]	5.4 [0.21]	M3 cap screw	5°	0.3 [0.01]	0.12 [0.005]	3.7 N·m	0.36 °/lb·in	
Aluminum (metric)	ARM-075-5-4D	\$51.50	TRD-MX (4mm)	4mm	5mm	19.1 [0.75]	19.1 [0.75]	4.6 [0.18]	2.4 [0.09]	M3 set screw	5°	0.25 [0.01]	0.25 [0.01]	2.3 N·m	8.2 N·m/rad	Aluminum alloy
	RU-075D	\$58.00	TRD-S/SR (6mm)	6mm	6mm	19.1 [0.75]	19.1 [0.75]	4.6 [0.18]	2.4 [0.09]	M3 set screw	5°	0.25 [0.01]	0.12 [0.005]	1.0 N·m	8.2 N·m/rad	
	JU-100D	\$51.50	TRD-N/NA (8mm)	8mm	8mm	25.4 [1.00]	25.4 [1.00]	6.6 [0.26]	3.8 [0.15]	M5 set screw	5°	0.25 [0.01]	0.25 [0.01]	1.6 N·m	14.3 N·m/rad	
	RU-100D	\$60.00	TRD-GK (10 mm)	10 mm	10 mm	25.4 [1.00]	25.4 [1.00]	6.6 [0.26]	3.8 [0.15]	M5 set screw	5°	0.25 [0.01]	0.12 [0.005]	1.6 N·m	14.3 N·m/rad	
Aluminum (metric-to-SAE)	ML13P-4-476D	\$51.50	TRD-MX (4mm)	4mm	0.1875 in	13 [0.51]	19 [0.75]	5.5 [0.22]	2.5 [0.10]	M2 set screw	5°	0.4 [0.02]	0.2 [0.01]	0.25 N·m	44 N·m/rad	Aluminum alloy (Bent plate: Polyimide)
	ML16P-4-635D	\$51.50	TRD-MX (4mm) TRDA-2E (0.25 in)	4mm	0.25 in	16 [0.63]	23 [0.91]	7 [0.28]	3 [0.12]	M3 set screw	5°	0.6 [0.02]	0.3 [0.01]	0.4 N·m	70 N·m/rad	
	MCGL16-6-635	\$33.00	TRD-S/SR (6mm) TRDA-2E (0.25 in)	6mm	0.25 in	16 [0.63]	23.2 [0.91]	7 [0.28]	3 [0.12]	M3 set screw	3.5°	0.3 [0.01]	0.3 [0.01]	0.4 N·m	70 N·m/rad	
	MCGL20-8-635	\$43.00	TRD-N/NA (8mm) TRDA-2E (0.25 in)	8mm	0.25 in	20 [0.79]	26 [1.02]	7.5 [0.30]	3.7 [0.15]	M3 set screw	3.5°	0.3 [0.01]	0.4 [0.02]	0.6 N·m	130 N·m/rad	
	MCGL20-8-952	\$44.00	TRD-N/NA (8mm) TRDA-20/25 (0.375 in)	8mm	0.375 in	20 [0.79]	26 [1.02]	7.5 [0.30]	3.7 [0.15]	M3 set screw	3.5°	0.3 [0.01]	0.4 [0.02]	0.6 N·m	130 N·m/rad	
	MCGL25-10-635	\$54.00	TRD-GK (10 mm) TRDA-2E (0.25 in)	10 mm	0.25 in	25 [0.98]	30.2 [1.19]	9 [0.35]	4 [0.16]	M4 set screw	3.5°	0.3 [0.01]	0.5 [0.02]	1.4 N·m	240 N·m/rad	
	MCGL25-10-952	\$55.00	TRD-GK (10 mm) TRDA-20/25 (0.375 in)	10 mm	0.375 in	25 [0.98]	30.2 [1.19]	9 [0.35]	4 [0.16]	M4 set screw	3.5°	0.3 [0.01]	0.5 [0.02]	1.4 N·m	240 N·m/rad	
Aluminum (SAE)	ARM-075-635-635D	\$52.00	TRDA-2E (0.25 in)	0.25 in	0.25 in	19.1 [0.75]	19.1 [0.75]	4.6 [0.18]	2.4 [0.09]	M3 set screw	5°	0.25 [0.01]	0.25 [0.01]	1.0 N·m	8.2 N·m/rad	Aluminum alloy
	ARM-100-9525-9525D	\$50.00	TRDA-20/25 (0.375 in)	0.375 in	0.375 in	25.4 [1.00]	25.4 [1.00]	6.6 [0.26]	3.8 [0.15]	M5 set screw	5°	0.25 [0.01]	0.25 [0.01]	1.6 N·m	14.3 N·m/rad	

* mm ÷ 25.4 = inches

Encoder Accessories – Couplings

Encoder Couplings – Dimensions

GJ-xxD Fiberglass Couplings (metric) & GJx-xxxD Fiberglass Couplings (SAE)

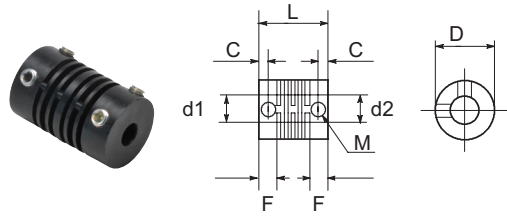

STP-MTRA-SC-xxxx Polymer Couplings

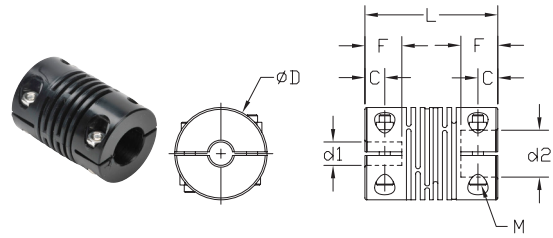

ARM-xxxxxxD Aluminum Couplings (metric & SAE)

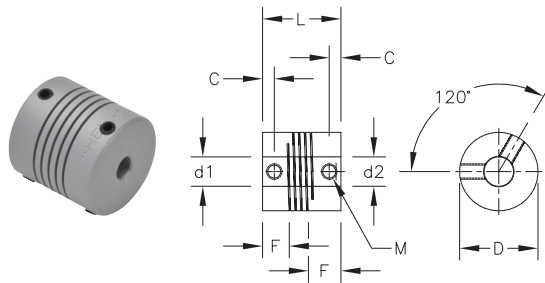

MCGLxx Aluminum Couplings & ML1xP-4-xxxD Aluminum Couplings

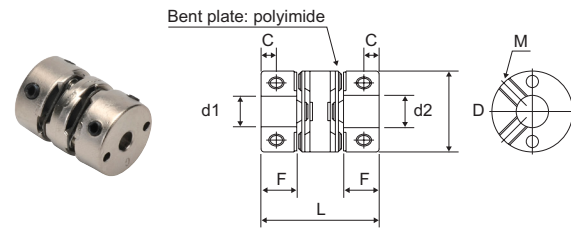

RU-075D, RU-100D, and JU-100D Aluminum Couplings

